

NOTES:

1. MATERIAL:
 - 1.1 HOUSING: THERMOPLASTIC, HIGH TEMP., UL94V-0; COLOR:BLACK.
 - 1.2 CONTACT: COPPER ALLOY
2. FINISH:
 - CONTACT:SEE ORDER INFORMATION.
 - UNDERPLATING: 50~100u" NICKEL OVERALL.
3. REFLOW SOLDER CAPABLE TO 260°C PER ACES SPEC.
4. SPEC. PLS. REFER TO PS-52936-xxxxx-xxx
5. PACKAGE PLS. REFER TO 52937-xxxCR-U
6. PART NUMBER

52937-XXX X X -XXX

CKTS _____ 001. ACES
 050.36+14 PIN _____
 PACKING _____ CONTACT PLATING
 0.TAPE REEL _____ D.Au 30u" ON CONTACT

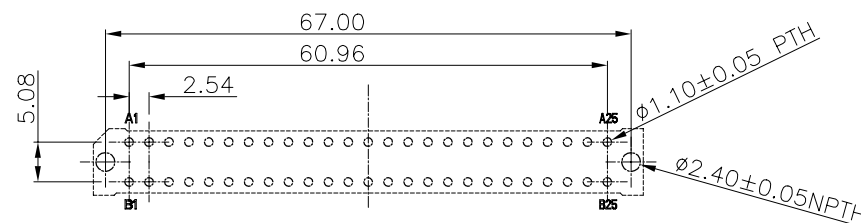
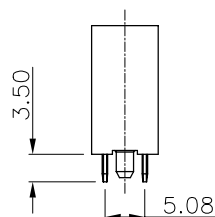
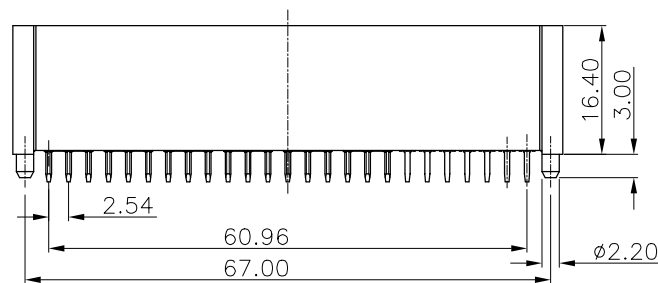

RECOMMEND P.C.B LAYOUT
 THICKNESS IS 2.0±0.1MM;DIMENSION
 TOLERANCE:±0.05MM

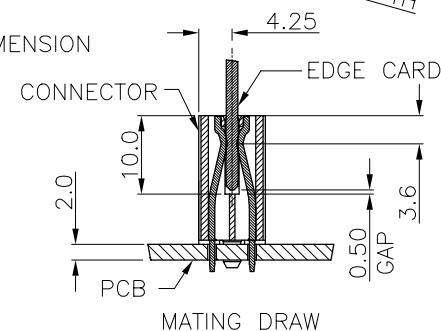
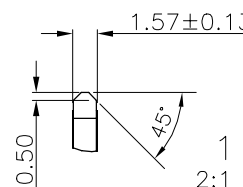
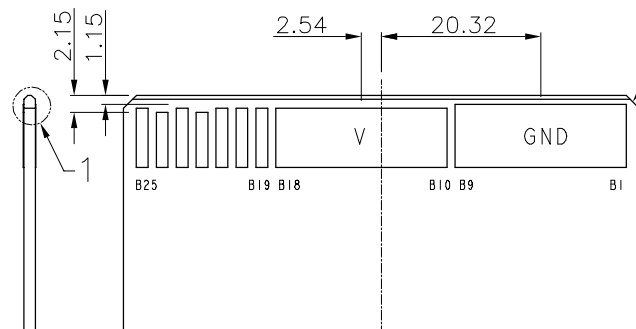
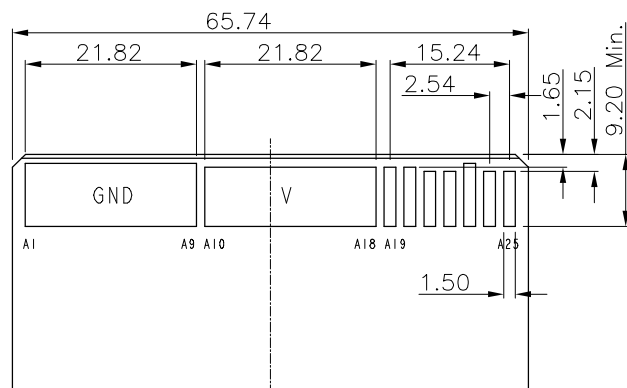

RECOMMEND EDGE CARD LAYOUT (TOP VIEW)
 THICKNESS IS 1.57±0.13MM;DIMENSION
 TOLERANCE:±0.05MM

QUALITY SYMBOLS MAJOR CRITICAL GENERAL TOLERANCES (UNLESS SPECIFIED) X. ±0.5 .X ±0.25 .XX ±0.15 .XXX ±0.1 ANGLES ±2°	DRAWN BY HSU YI LUN DATE 21/08/03	 ACES ELECTRONICS TITLE 2.54 mm POWER CONN. VERTICAL TYPE
	CHECKED BY CHEN CHUN YUAN DATE 21/08/03	
APPROVED BY HUANG KUO HUA DATE 21/08/03	UNITS mm	SIZE A4
SCALE 1 : 1	SHEET NO. 1 OF 2	REV D
		DWG NO. 52937-xxxxx-xxx

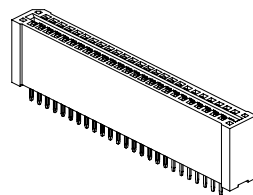
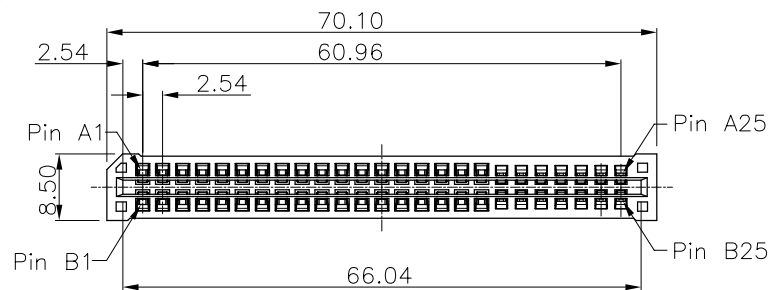

NOTES:

1. MATERIAL:
 - 1.1 HOUSING: THERMOPLASTIC, HIGH TEMP., UL94V-0; COLOR:BLACK.
 - 1.2 CONTACT: COPPER ALLOY
2. FINISH:
 - CONTACT:SEE ORDER INFORMATION.
 - UNDERPLATING: 50~100u" NICKEL OVERALL.
3. REFLOW SOLDER CAPABLE TO 260°C PER ACES SPEC.
4. SPEC. PLS. REFER TO PS-52936-xxxxx-xxx
5. PACKAGE PLS. REFER TO 52937-xxxCR-U
6. PART NUMBER

52937-XXX X X -XXX

CKTS _____ 002. WITHOUT POST
 050.36+14 PIN
 PACKING _____ CONTACT PLATING
 0.TAPE REEL D.Au 30u" ON CONTACT

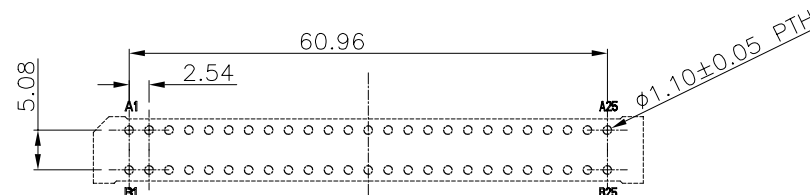
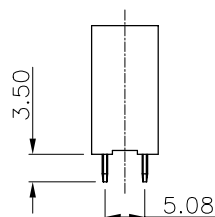
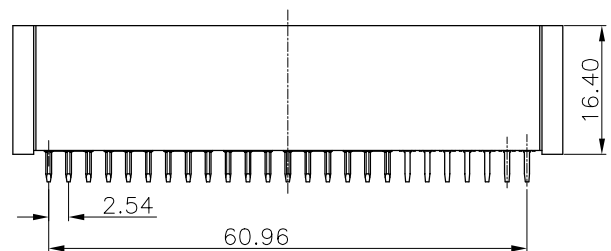

RECOMMEND P.C.B LAYOUT
 THICKNESS IS 2.0±0.1MM;DIMENSION
 TOLERANCE:±0.05MM

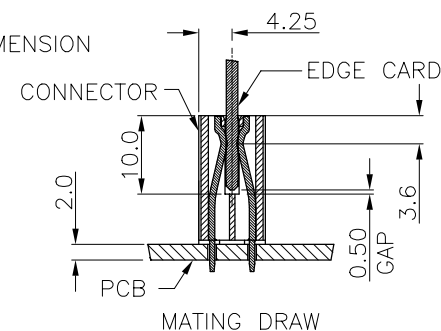
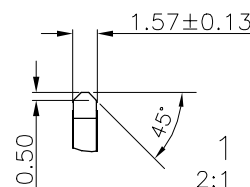
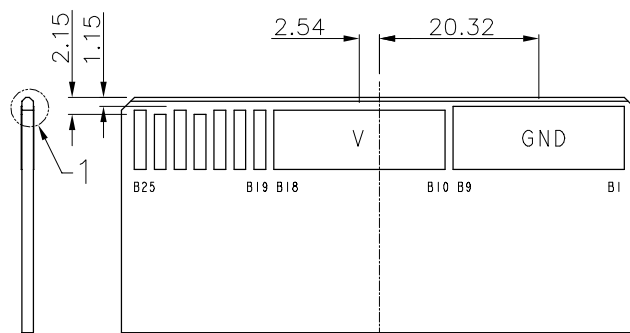
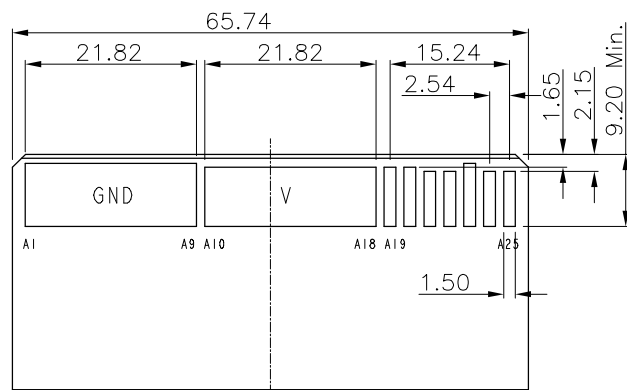

RECOMMEND EDGE CARD LAYOUT (TOP VIEW)
 THICKNESS IS 1.57±0.13MM;DIMENSION
 TOLERANCE:±0.05MM

QUALITY SYMBOLS MAJOR CRITICAL GENERAL TOLERANCES (UNLESS SPECIFIED) X. ±0.5 .X ±0.25 .XX ±0.15 .XXX ±0.1 ANGLES ±2°	DRAWN BY HSU YI LUN DATE 21/08/03	
	CHECKED BY CHEN CHUN YUAN DATE 21/08/03	
	APPROVED BY HUANG KUO HUA DATE 21/08/03	RFG NO. N/A
UNITS mm		SIZE A4
SCALE 1 : 1	SHEET NO. 2 OF 2	REV D
		DWG NO. 52937-xxxxx-xxx